



SIEMENS
Ingenuity for life

Solid Edge CAM Pro

Delivering machine tool value

Benefits

- Get the most out of your tools using the latest manufacturing techniques
- Maximize shop floor efficiency with a single unified CAM system
- Work directly with Solid Edge parts and assemblies, maintaining associativity
- Low cost of ownership, easy to deploy, learn and use

Features

- Scalable solutions offer wide-ranging capabilities, including turning, milling and feature-based machining
- Tutorials, templates and wizards simplify use
- Seamless integration with Solid Edge mechanical design, launch with one click
- Postprocessing and machine simulation

Summary

Solid Edge® CAM Pro software, a capable, proven computer-aided manufacturing (CAM) solution from Siemens, features a rich set of tools to help you finish the job right the first time. Solid Edge CAM Pro is a modular, flexible configuration of numerical control (NC) programming solutions that allows you to maximize the value of your machine tools. Designed with Solid Edge users in mind, CAM Pro provides powerful NC programming with a low total cost of ownership and is easy to deploy, learn and use.

Powerful, yet easy to use

Solid Edge CAM Pro helps manufacturers define and execute a wide range of manufacturing processes, including milling, turning and feature-based machining, with comprehensive machining simulation.

Solid Edge CAM Pro delivers accurate and efficient manufacturing processes working directly with Solid Edge parts and assemblies. Sending files from Solid Edge to CAM Pro is as easy as one click, and the data retains associativity so that late-stage design changes can be easily incorporated into the manufacturing plan.

An intuitive, modern user interface (UI), easy-to-follow tutorials, built-in templates and wizards make Solid Edge CAM Pro remarkably easy to use.

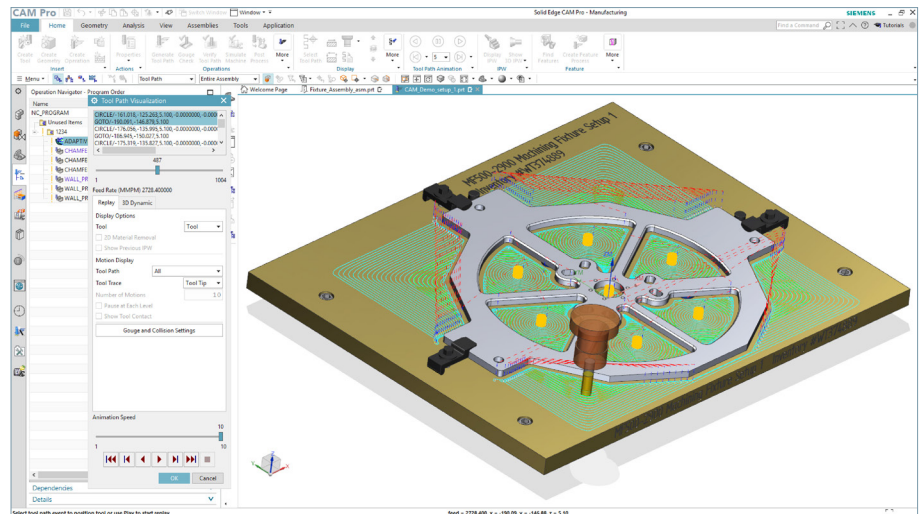

Solid CAM Pro

Consistent navigators manage key elements while dialogs provide graphical help and instant feedback in the graphics area. Templates are used extensively throughout the system to capture and re-apply methods, geometry, setups, operations and tool selections. Built-in wizards and the ability to create custom wizards take the user to the next level of automated interaction. Fifteen easy-to-follow tutorials can help users initially learn the powerful software and can be revisited later as a refresher.

Full range of capabilities

Avoid the need for (and the cost of) multiple CAM systems in the machine shop with Solid Edge CAM Pro. The scalable solution offers a wide range of in-depth NC programming capabilities, providing flexibility and maximizing the value of your investment.

Drilling – addresses drilling, reaming, boring, tapping, peck drilling and custom cycles. Automated hole making is available with the feature-based machining options.

2.5-axis milling – 2.5-axis roughing patterns can be applied based on basic boundary data or solid geometry. Zig-zag, offset, and plunge milling are examples of the toolpaths provided, and high-speed roughing toolpaths such as trochoidal are available. Feature-based machining functions automate the identification and programming of slots and faces.

Turning – a complete solution that is easy enough to use on simple programs and capable enough to tackle your toughest geometry in multi-spindle, multi-turret applications. The system can work with solids, wireframe or 2D profiles.

3-axis milling – for roughing, rest milling, semi-finishing and finishing of contoured surfaces, with a complete set of milling strategies to address the challenges of complex geometry. This capability includes additional functions needed for high-speed machining.

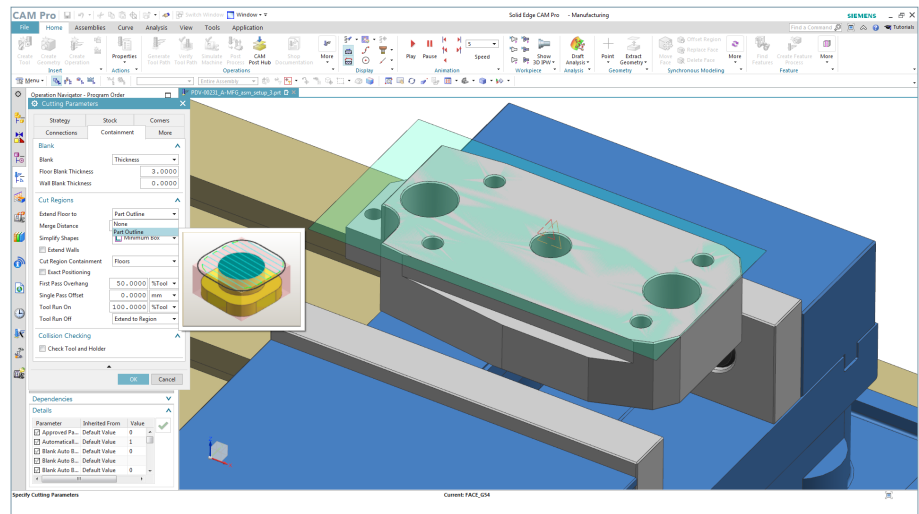

Wire EDM – a complete solution for programming 2- to 4-axis wire electrical discharge machining (EDM) machines. A range of wire operations is available, including multi-pass profiling, wire reversing and area removal.

Synchronization – a graphical means of displaying an unlimited number of channels, with scrolling code in a choice of formats, time displays and with functions to add wait and sync codes. The synchronization manager is directly linked to the internal postprocessor and runs from posted output for the greatest accuracy.

Machining simulation – to avoid tying up a machine in unproductive prove-outs, the integrated machine tool simulation provides a more complete simulation than most systems with its machine-code-driven motion.

5-axis milling – Solid Edge CAM Pro offers highly flexible 5-axis programming functions combining automated elements for tedious tasks such as geometry selection and detailed user control for precise machining.

Tool path visualization and editing

You can have confidence with tool path visualization and material removal verification tools. Integrated collision checking identifies any possible problems. You can also make fast changes to tool path results with graphical editing functions and protect your edits by locking tool paths from future recalculations.

Postprocessing

CAM Pro has a comprehensive postprocessing capability that allows posts to be handled easily. You can edit and fine-tune existing postprocessors with the interactive post builder application or even build a postprocessor from scratch using post builder templates. In addition, you can use included sample posts or download a post from the support library.

Shop documentation

You can produce HTML setup documents with the included shop doc capability. Product manufacturing information (PMI) is transferred along with geometry data from Solid Edge to Solid Edge CAM Pro. That makes it easy for the NC programmers to design the manufacturing plan according to the engineer's specifications.

Key feature/function	CAM Pro Foundation	CAM Pro Total Machining	CAM Pro 5-Axis Milling
Gateway and CAM Base	X	X	X
Industry translators	X	X	X
2D data exchange	X	X	X
Rapid prototyping	X	X	X
Knowledge Fusion sharing	X	X	X
Assemblies	X	X	X
Model edit toolbar	X	X	X
Machining wizard builder	X	X	X
Library access	X	X	X
Toolpath and material removal visualization	X	X	X
Graphical toolpath editing	X	X	X
Postprocessing	X	X	X
Post builder and post configurator	X	X	X
Shop documentation	X	X	X
Work instruction authoring	X	X	X
Planar milling	Add-on	X	X
Face milling	Add-on	X	X
Cavity milling	Add-on	X	X
Z-level profiling	Add-on	X	X
Feature-based machining	Add-on	X	X
Generic motion control	Add-on	X	X
Probing	Add-on	X	X
3+2-axis positioning	Add-on	X	X
Fixed-axis area milling	Add-on	X	X
Flow cut for valley rest milling	Add-on	X	X
Streamline milling	Add-on	X	X
Cut between levels for semi-finishing	Add-on	X	X
NURBS and spline output	Add-on	X	X
Facet machining	Add-on	X	X
Adaptive clearance strategy	Add-on	X	X
Sequential milling for user control	Add-on	X	X
Variable-axis surface milling	Add-on	X	X
Contour profiling for swarf cutting	Add-on	X	X
3- to 5-axis milling (tilt-tool)	Add-on	X	X
Turning	Add-on	X	Add-on
4-axis wire EDM	Add-on	X	Add-on
Integrated simulation and verification	Add-on	X	Add-on
ISV: tool path driven	Add-on	X	Add-on
ISV: G-code driven	Add-on	X	Add-on
Multi-channel synchronization	Add-on	X	Add-on
Machine tool builder	Add-on	X	Add-on
Machining knowledge editor	Add-on	X	Add-on
Turbomachinery milling	Add-on	Add-on	Add-on

Optimized with Solid Edge, CAD neutral

Optimized when integrated with Solid Edge mechanical design, CAM Pro can also be used independently of any specific CAD system. Key industry translators can read data formats from practically any CAD system, including Siemens Parasolid® software, IGES, DXF, STEP and JT formats. In addition, you can save data in all these formats, plus STL.

Extending value

Solid Edge is a portfolio of affordable, easy to deploy, maintain and use software tools that advance all aspects of the product development process - mechanical and electrical design, simulation, manufacturing, technical documentation, data management and cloud-based collaboration.

At the heart of the Solid Edge portfolio is Siemens Parasolid software, the most widely used computer-aided geometric modeling kernel in the industry. Parasolid enables the creation and modification of digital 3D models and delivers 100 percent 3D model compatibility between product development applications such as design, simulation and manufacturing.

Minimum system configuration

- Windows 10 Enterprise or Professional (64-bit only) version 1709 or later
- 8 GB RAM
- 65K colors
- Screen resolution: 1920 x 1080
- 6.5 GB of disk space required for installation

Siemens Digital Industries Software
[siemens.com/plm](https://www.siemens.com/plm)

Americas +1 314 264 8499
Europe +44 (0) 1276 413200
Asia-Pacific +852 2230 3333

Restricted © Siemens 2019. Siemens, the Siemens logo and SIMATIC IT are registered trademarks of Siemens AG. Camstar, D-Cubed, Femap, Fibersim, Geolus, GO PLM, I-deas, JT, NX, Parasolid, Polarion, Simcenter, Solid Edge, Syncrofit, Teamcenter and Tecnomatix are trademarks or registered trademarks of Siemens Product Lifecycle Management Software Inc. or its subsidiaries or affiliates in the United States and in other countries. All other trademarks, registered trademarks or service marks belong to their respective holders.
78035-C2 6/19 M